

REV	DESCRIPTION	DATE

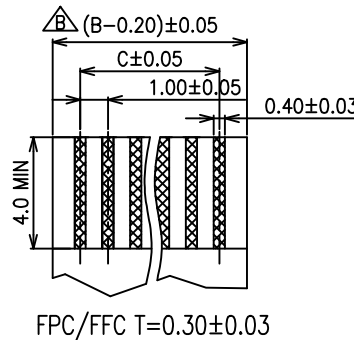
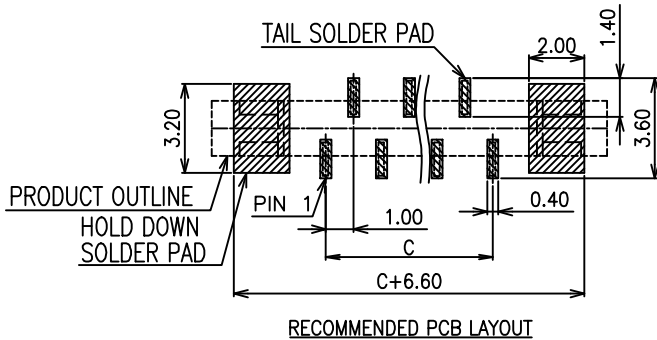
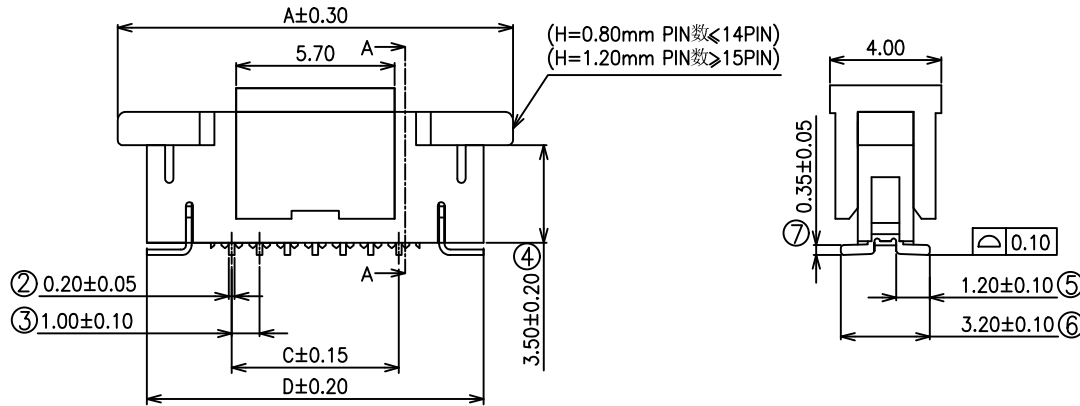
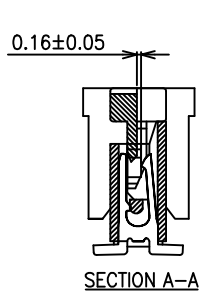
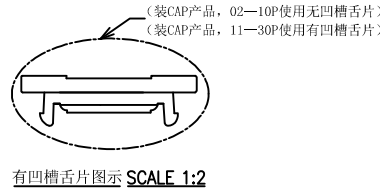
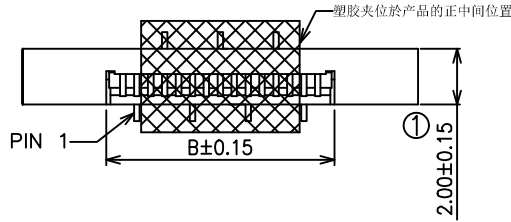

NOTE:

- MATERIAL
HOUSING:HIGH-TEMP. THERMOPLASTIC. UL 94V-0.
ACTUATOR:HIGH-TEMP. THERMOPLASTIC. UL 94V-0.
CONTACT:PHOSPHOR BRONZE.
PLATING:TIN OR GOLD PLATED OVER NICKEL.
HOLDDOWN:BRASS. PLATING:TIN PLATED OVER NICKEL.
- ELECTRICAL
CURRENT:0.5A MAX.
DIELECTRIC WITHSTANDING VOLTAGE:250V AC MIN.
CONTACT RESISTANCE:30mΩ MAX.
INSULATION RESISTANCE:100MΩ MIN.
- ENVIRONMENTAL
TEMPERATURE:-25°C TO +85°C
- WITH "A","B","C","D","O" MAJOR DIMENSION FOR QC.
- PART NO.
CNT-FPC100-XX-TSM-D11-350

■ DIMENSIONAL INFORMATION

PIN数	Dimension				PIN数	Dimension			
	A	B	C	D		A	B	C	D
2	9.20	3.20	1.00	7.10	20	27.20	21.20	19.00	25.10
3	10.20	4.20	2.00	8.10	21	28.20	22.20	20.00	26.10
4	11.20	5.20	3.00	9.10	22	29.20	23.20	21.00	27.10
5	12.20	6.20	4.00	10.10	23	30.20	24.20	22.00	28.10
6	13.20	7.20	5.00	11.10	24	31.20	25.20	23.00	29.10
7	14.20	8.20	6.00	12.10	25	32.20	26.20	24.00	30.10
8	15.20	9.20	7.00	13.10	26	33.20	27.20	25.00	31.10
9	16.20	10.20	8.00	14.10	27	34.20	28.20	26.00	32.10
10	17.20	11.20	9.00	15.10	28	35.20	29.20	27.00	33.10
11	18.20	12.20	10.00	16.10	29	36.20	30.20	28.00	34.10
12	19.20	13.20	11.00	17.10	30	37.20	31.20	29.00	35.10
13	20.20	14.20	12.00	18.10					
14	21.20	15.20	13.00	19.10					
15	22.20	16.20	14.00	20.10					
16	23.20	17.20	15.00	21.10					
17	24.20	18.20	16.00	22.10					
18	25.20	19.20	17.00	23.10					
19	26.20	20.20	18.00	24.10					

<p>CNT 肯耐特电子有限公司</p>				GENERAL TOLERANCE		DRAWN 董道丽	DATE 20191011	DWG. NO.	TITLE
				X.° ±5°	X. ±0.30				
REV. 1.0	UNIT mm	SCALE 1:1		.X° ±3°	.X ±0.38	APPROVE 王元中	DATE 20191011	PART. NO. CNT-FPC100-XX-TSM-D11-350	FPC PITCH 1.0mm 立式正脚位 SMT180°
				.XX° ±2°	.XX ±0.25				
				.XXX° ±1°	.XXX ±0.15				