

REV	DESCRIPTION	DATE

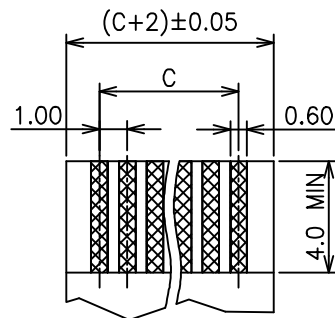

FPC/FFC T=0.30±0.05

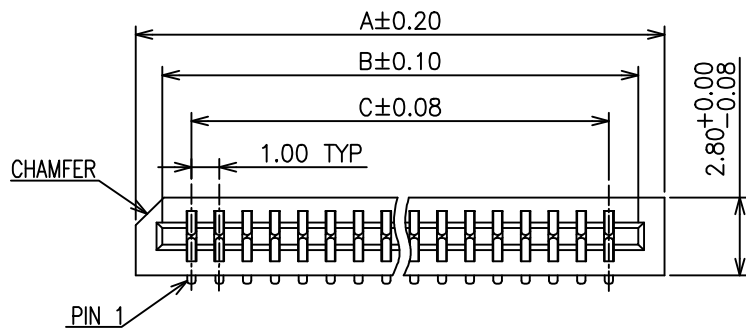
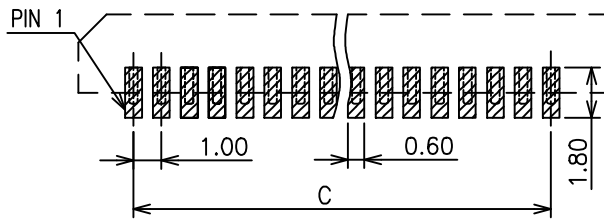
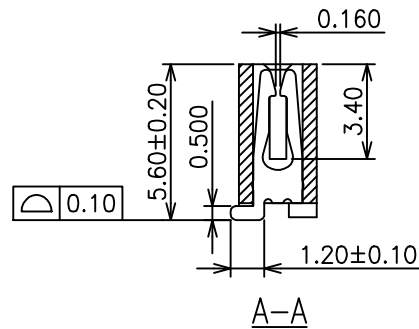
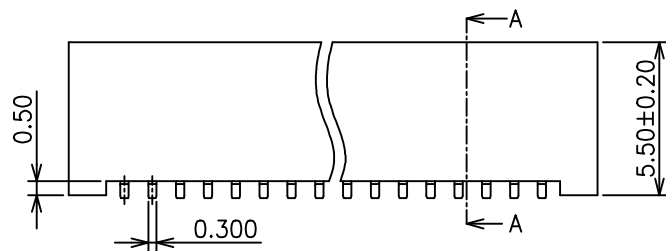

RECOMMENDED PCB LAYOUT

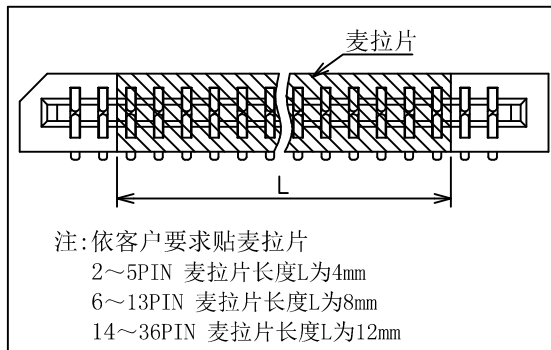

NOTE:

■ MATERIAL

HOUSING: GLASS-REINFORCED THERMOPLASTIC UL 94V-0.
 CONTACT: COPPER ALLOY.
 PLATING: TIN PLATED OVER NICKEL.

■ ELECTRICAL

CURRENT RATING: 1.0 AMP.
 DIELECTRIC WITHSTANDING VOLTAGE: 500V AC MIN.
 INSULATION RESISTANCE: 500MΩ MIN.
 CONTACT RESISTANCE: 30mΩ MAX.

■ ENVIRONMENTAL

TEMPERATURE RANGE: -25°C TO 85°C.

■ PART NO.

CNT-FPC100-XX-TSM-D3-550

■ DIMENSION TABLE

Circuits	Dimension			Circuits	Dimension		
	A	B	C		A	B	C
2	5.00	3.10	1.00	20	23.00	21.10	19.00
3	6.00	4.10	2.00	21	24.00	22.10	20.00
4	7.00	5.10	3.00	22	25.00	23.10	21.00
5	8.00	6.10	4.00	23	26.00	24.10	22.00
6	9.00	7.10	5.00	24	27.00	25.10	23.00
7	10.00	8.10	6.00	25	28.00	26.10	24.00
8	11.00	9.10	7.00	26	29.00	27.10	25.00
9	12.00	10.10	8.00	27	30.00	28.10	26.00
10	13.00	11.10	9.00	28	31.00	29.10	27.00
11	14.00	12.10	10.00	29	32.00	30.10	28.00
12	15.00	13.10	11.00	30	33.00	31.10	29.00
13	16.00	14.10	12.00	31	34.00	32.10	30.00
14	17.00	15.10	13.00	32	35.00	33.10	31.00
15	18.00	16.10	14.00	33	36.00	34.10	32.00
16	19.00	17.10	15.00	34	37.00	35.10	33.00
17	20.00	18.10	16.00	35	38.00	36.10	34.00
18	21.00	19.10	17.00	36	39.00	37.10	35.00
19	22.00	20.10	18.00				

<p>CNT 肯耐特电子有限公司</p>				GENERAL TOLERANCE	DRAWN	DATE	DWG. NO.	TITLE	
				X.° ±5°	X.	董道丽			20191011
REV. 1.0	UNIT mm	SCALE 1:1		.X° ±3°	CHECK	DATE	PART. NO.	FPC 1.0 PITCH CONNECTOR TOP ENTRY DUAL SMT TYPE 单边平脚位	
				.XX° ±2°	.X	王芳芳			20191011
				.XXX° ±1°	.XXX	王元中			20191011
							CNT-FPC100-XX-TSM-D3-550		