

REV	DESCRIPTION	DATE

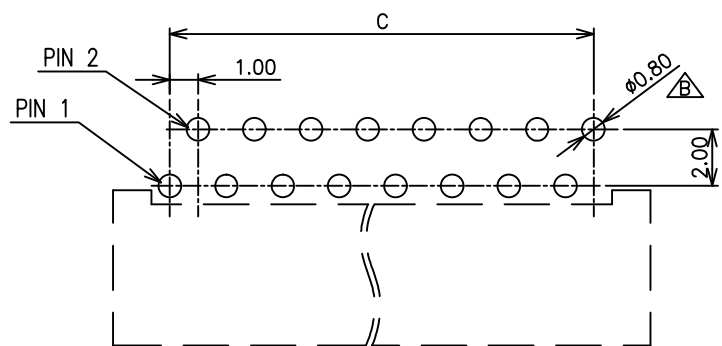

RECOMMENDED PCB LAYOUT

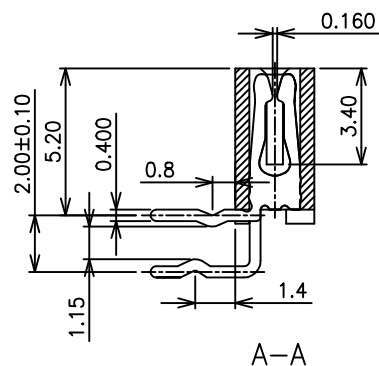
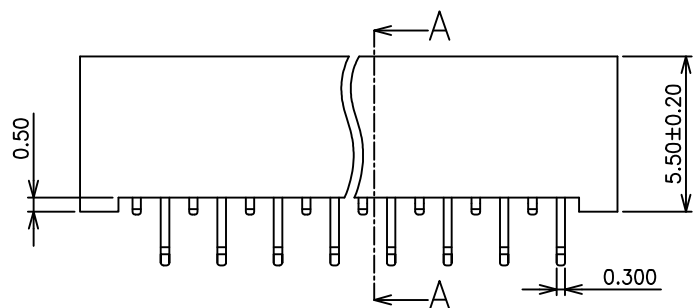
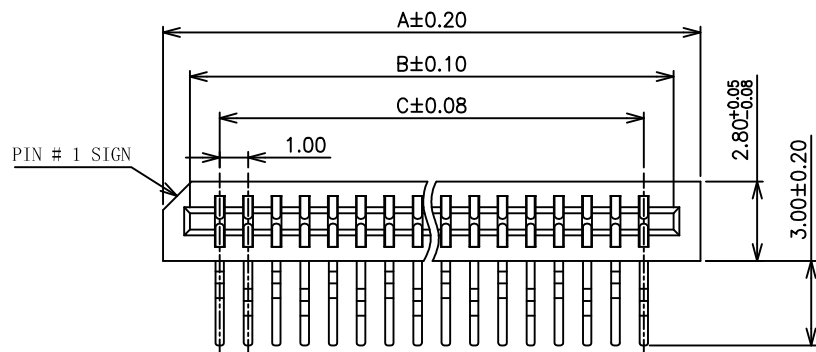
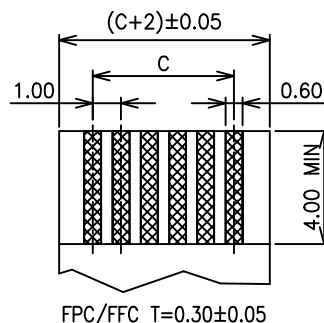

NOTE:

- MATERIAL
HOUSING: GLASS-REINFORCED THERMOPLASTIC UL 94V-0.
CONTACT: COPPER ALLOY.
PLATING: TIN PLATED OVER NICKEL
- ELECTRICAL
CURRENT RATING: 1.0AMP.
DIELECTRIC WITHSTANDING VOLTAGE: 500V AC MIN.
INSULATION RESISTANCE: 500MΩ MIN.
CONTACT RESISTANCE: 30mΩ MAX.
- ENVIRONMENTAL
TEMPERATURE RANGE: -25°C TO +85°C.
- PART NO.
CNT-FPC100-XX-TD-D2-550

■ DIMENSION TABLE

Circuits	Dimension			Circuits	Dimension		
	A	B	C		A	B	C
2	5.00	3.10	1.00	20	23.00	21.10	19.00
3	6.00	4.10	2.00	21	24.00	22.10	20.00
4	7.00	5.10	3.00	22	25.00	23.10	21.00
5	8.00	6.10	4.00	23	26.00	24.10	22.00
6	9.00	7.10	5.00	24	27.00	25.10	23.00
7	10.00	8.10	6.00	25	28.00	26.10	24.00
8	11.00	9.10	7.00	26	29.00	27.10	25.00
9	12.00	10.10	8.00	27	30.00	28.10	26.00
10	13.00	11.10	9.00	28	31.00	29.10	27.00
11	14.00	12.10	10.00	29	32.00	30.10	28.00
12	15.00	13.10	11.00	30	33.00	31.10	29.00
13	16.00	14.10	12.00	31	34.00	32.10	30.00
14	17.00	15.10	13.00	32	35.00	33.10	31.00
15	18.00	16.10	14.00	33	36.00	34.10	32.00
16	19.00	17.10	15.00	34	37.00	35.10	33.00
17	20.00	18.10	16.00	35	38.00	36.10	34.00
18	21.00	19.10	17.00	36	39.00	37.10	35.00
19	22.00	20.10	18.00				

<h1 style="margin: 0;">CNT</h1> <p style="margin: 0;">肯耐特电子有限公司</p>				GENERAL TOLERANCE		DRAWN 董道丽		DATE 20191011		DWG. NO.		TITLE	
				X.° ±5°	X. ±0.30	CHECK 王芳芳		DATE 20191011					
<p>REV. 1.0 UNIT mm SCALE 1:1</p>				.X° ±3°	.X ±0.38	APPROVE 王元中		DATE 20191011		PART. NO. CNT-FPC100-XX-TD-D2-550		FPC 1.0 PITCH CONNECTOR SIDEENTRY DUAL CONTACT DIP TYPE	
				.XX° ±2°	.XX ±0.25								
				.XXX° ±1°	.XXX ±0.15								