

ROHS

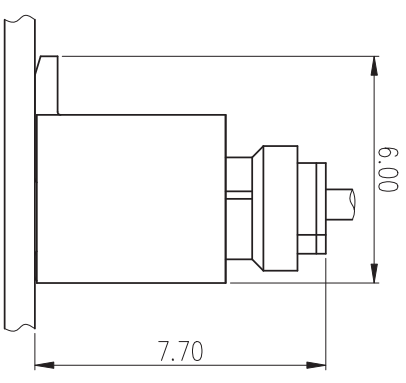
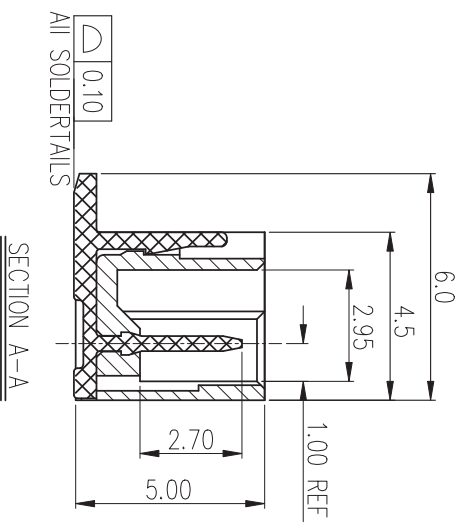
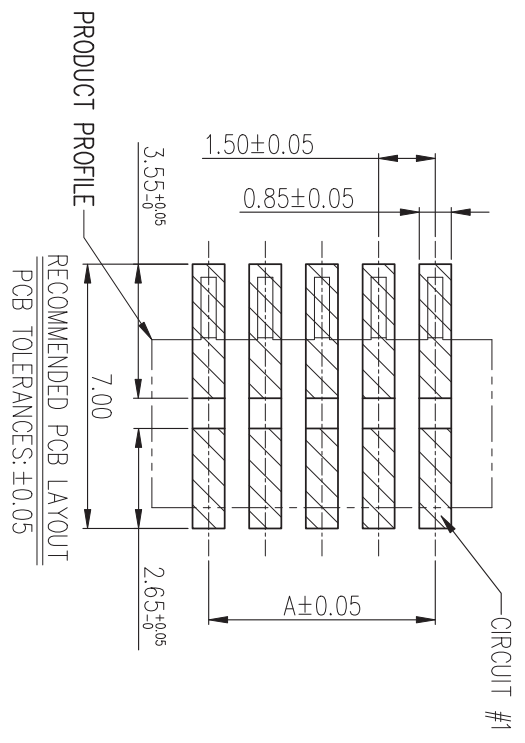
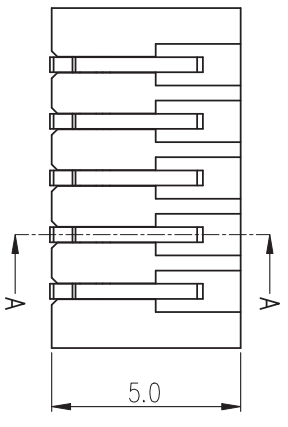
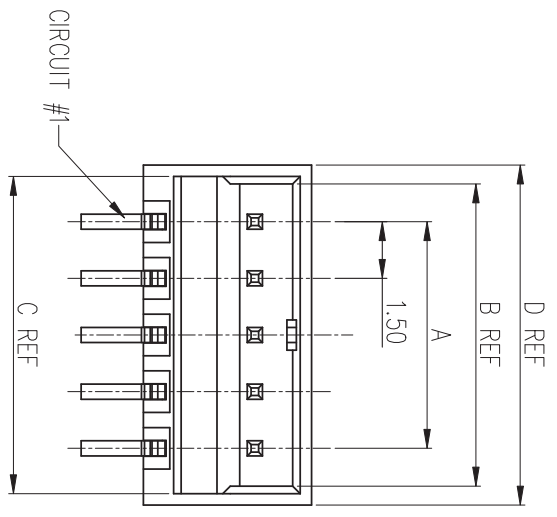

- NOTES:
- MATERIAL SPECIFICATION
 - INSULATION: NYLON 9T, UL 94V-0.
 - CONTACT: THICK 0.40mm BRASS.
 - PLATING SPECIFICATION
 - CONTACT: TIN/GOLD PLATED.
 - BILL OF PART NO: 1502WVS-XP-XX
 - NO. OF CIRCUITS: 2~15
 - FOR COLOR AVAILABILITY, DELIVERY & MOQ, CONTACT CNT. DIMENSIONAL
- COLOR: BLANK(NATURAL) OR A~Z
FINISH: A=MATTE TIN PLATED
B=BRIGHT TIN PLATED

| POS | A | B | C | D |
|-----|------|------|------|------|
| 2 | 1.5 | 3.5 | 3.9 | 4.5 |
| 3 | 3.0 | 5.0 | 5.4 | 6.0 |
| 4 | 4.5 | 6.5 | 6.9 | 7.5 |
| 5 | 6.0 | 8.0 | 8.4 | 9.0 |
| 6 | 7.5 | 9.5 | 9.9 | 10.5 |
| 7 | 9.0 | 11.0 | 11.4 | 12.0 |
| 8 | 10.5 | 12.5 | 12.9 | 13.7 |
| 9 | 12.0 | 14.0 | 14.4 | 15.0 |
| 10 | 13.5 | 15.5 | 15.9 | 16.5 |
| 11 | 15.0 | 17.0 | 17.4 | 18.0 |
| 12 | 16.5 | 18.5 | 18.9 | 19.5 |
| 13 | 18.0 | 20.0 | 20.4 | 21.0 |
| 14 | 19.5 | 21.5 | 21.9 | 22.5 |
| 15 | 21.0 | 23.0 | 23.4 | 24.0 |

| | | | |
|------|----------------------|-----------------|------------|
| C | ADDS PACKING DIAGRAM | Rock | 2017.01.07 |
| B | UPGRADE DRAWING | Rock | 2016.01.28 |
| REV. | ECN ND | REVISION RECORD | DRAW DATE |
| 1 | 1 | 2 | 3 |

| | | | | | |
|------------|------------------|---------------|------------|---------------------------------------------------------|-------------|
| TOLERANCE | | PART NO. | | C N 特耐特电子有限公司 | |
| X.X ±0.30 | X.XXX ±0.10 | 1502WVS-XP-XX | | | |
| X.XX ±0.20 | Angular ±2° | DRAWING NO. | | DESCRIPTION WTB 1502 SERIES 1.5mm PITCH V/T SMT TYPE | |
| UNIT: mm | | C-15020202-XX | | | |
| DWG TYPE: | Customer Drawing | APPROVED BY | CHECKED BY | DRAWN BY | PAGE |
| | | | | | 1 OF 2 |
| | | | | | SCALE 5 : 1 |
| | | | | | REV. C |

ROHS

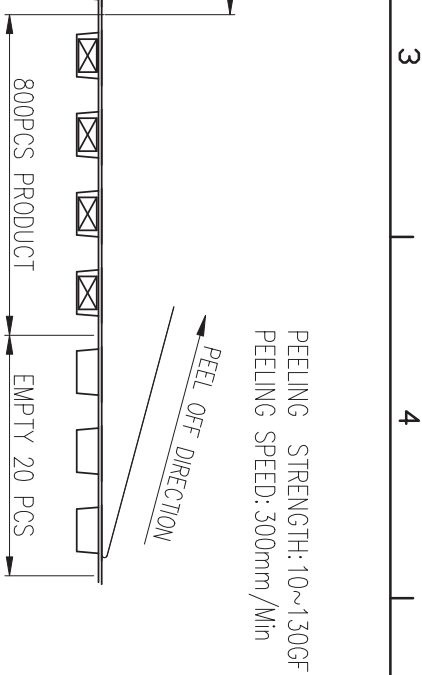
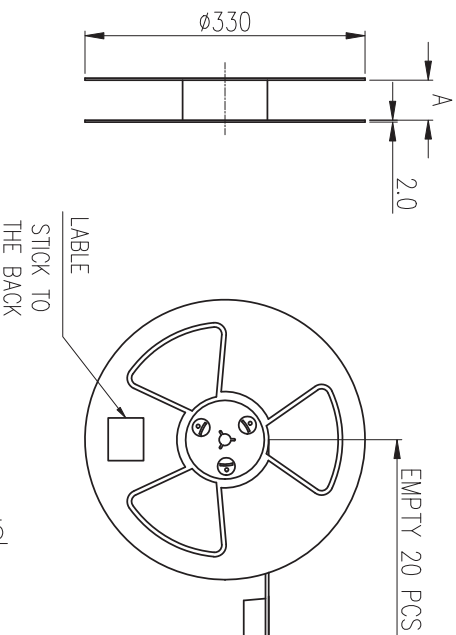

PEELING STRENGTH: 10~130GF
PEELING SPEED: 300mm/Min

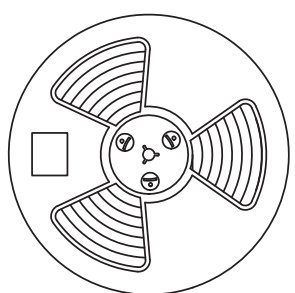

TABLE 2:

| POS | PCS/REEL | PCS/CARTON | NET WEIGHT (KG) | GROSS WEIGHT (KG) |
|-----|----------|------------|-----------------|-------------------|
| 2 | 800 | 7200 | 0.99 | 4.74 |
| 3 | 800 | 7200 | 1.32 | 5.07 |
| 4 | 800 | 7200 | 1.66 | 5.41 |
| 5 | 800 | 4800 | 1.32 | 4.02 |
| 6 | 800 | 4800 | 1.55 | 4.25 |
| 7 | 800 | 4800 | 1.77 | 4.47 |
| 8 | 800 | 4800 | 1.99 | 4.69 |
| 9 | 800 | 4800 | 2.21 | 4.91 |
| 10 | 800 | 3200 | 1.62 | 3.62 |
| 11 | 800 | 3200 | 1.77 | 3.77 |
| 12 | 800 | 3200 | 1.91 | 3.91 |
| 13 | 800 | 3200 | 2.06 | 4.06 |
| 14 | 800 | 3200 | 2.21 | 4.21 |
| 15 | 800 | 3200 | 2.36 | 4.36 |

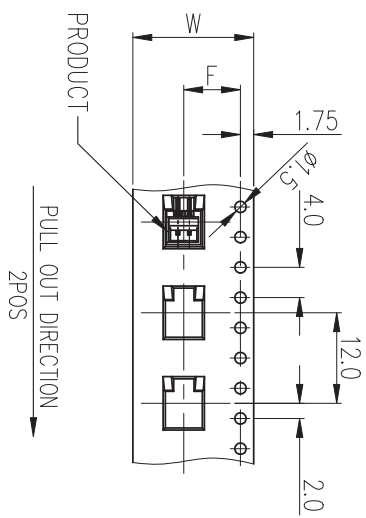
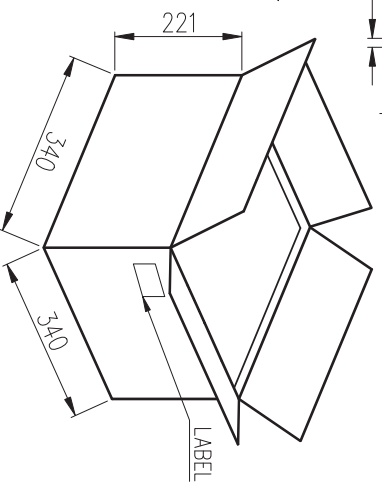
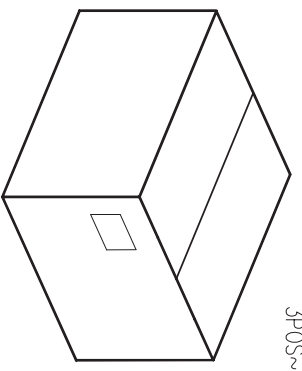
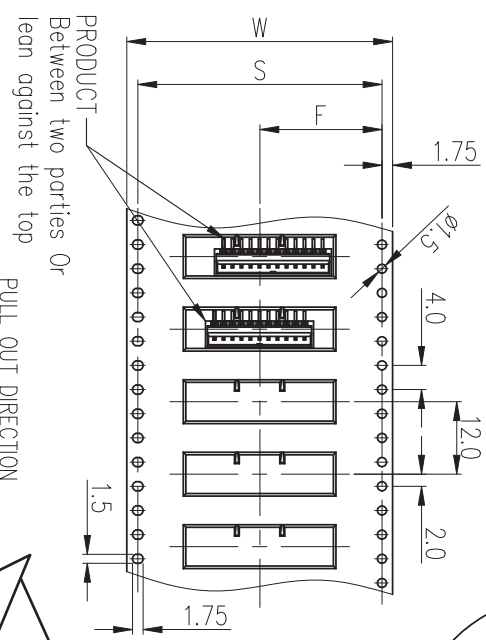

TABLE 1:

| POS. | A | W | S | F |
|-------|------|------|------|------|
| 2~4 | 16.5 | 16.0 | | 7.5 |
| 5~9 | 24.5 | 24.0 | | 11.5 |
| 10~15 | 44.5 | 44.0 | 40.4 | 20.2 |



| REV. | ECN NO | REVISION RECORD | DRAW | DATE |
|------|--------|----------------------|------|------------|
| B | | UPGRADE DRAWING | Rock | 2016.01.28 |
| C | | ADDS PACKING DIAGRAM | Rock | 2017.01.07 |

| | | | | | |
|---------------------------------------------------------------|--|-------------------------------------|--|---------------------------------------------------------------------------|--|
| TOLERANCE X.XXX ±0.30 X.XXX ±0.20 Angular ±2° | | PART NO. 1502WVS-XP-XX | | C N 肯耐特电子有限公司 | |
| DWG TYPE. Customer Drawing | | DRAWING NO. C-15020202-XX | | DESCRIPTION WTB 1502 SERIES 1.5mm PITCH V/T SMT TYPE PACKING | |
| UNIT: mm | | APPROVED BY | | DRAWN BY | |
| Customer Drawing | | CHECKED BY | | SCALE 5 : 1 | |
| Customer Drawing | | REV. C | | REV. C | |