

RoHS

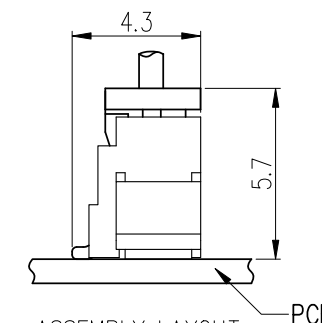

CUST INFORMATION.

PART NO. NA	DRAWING NO. NA	REV. NA
----------------	-------------------	------------

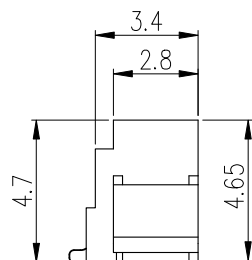
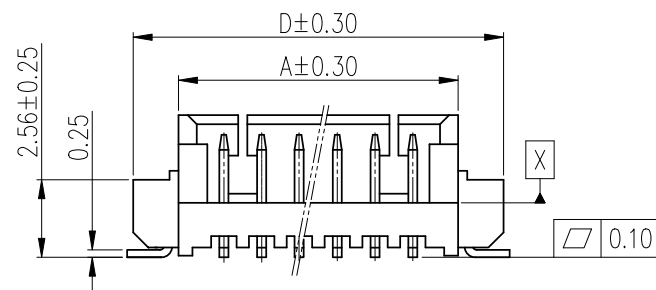
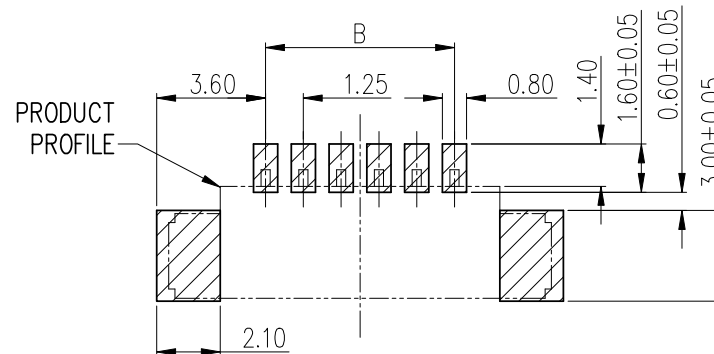
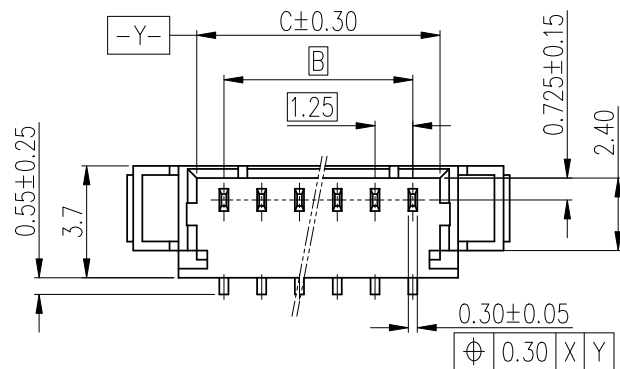

ASSEMBLY LAYOUT  
TOP ENTRY TYPE

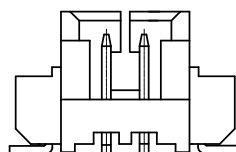
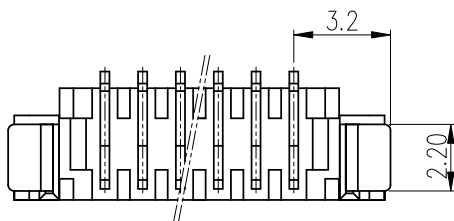

2 POS

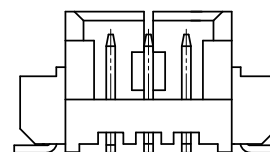

3 POS

NOTE:

- MATERIAL:  
HOUSING: THERMOPLASTIC, UL94 V-0, COLOR: NATURAL  
TERMINAL AND HOLD DOWN: COPPER ALLOY.
- CONTACT FINISH:  
UNDERPLATING NICKEL OVERALL, DETAIL SEE NOTE 4.
- HOLD DOWN FINISH: MATTE TIN PLATING OVER NICKEL.
- ORDER INFORMATION:

CNT1253WD X 0 X 4 - XX HF

- PACKAGING:   
 1: BAG   
 2: TAPE REEL   
 3: TUBE   
 4: BOX
- NO. OF POS  
ROW: 02~15
- PLATING OPTIONS:  
 0: MATTE TIN OVERALL.  
 1: GOLD FLASH ON CONTACT AREA  
 MATTE TIN ON SOLDER AREA.

5. DIMENSIONAL & ORDERING INFORMATION:

PART NO.	POS	A	B	C	D
1253WDXXX4-02HF	2	4.25	3.05	7.25	
1253WDXXX4-03HF	3	5.50	2.50	4.30	8.50
1253WDXXX4-04HF	4	6.75	3.75	5.55	9.75
1253WDXXX4-05HF	5	8.00	5.00	6.80	11.00
1253WDXXX4-06HF	6	9.25	6.25	8.05	12.25
1253WDXXX4-07HF	7	10.50	7.50	9.30	13.50
1253WDXXX4-08HF	8	11.75	8.75	10.55	14.75
1253WDXXX4-09HF	9	13.00	10.00	11.80	16.00
1253WDXXX4-10HF	10	14.25	11.25	13.05	17.25
1253WDXXX4-11HF	11	15.50	12.50	14.30	18.50
1253WDXXX4-12HF	12	16.75	13.75	15.55	19.75
1253WDXXX4-13HF	13	18.00	15.00	16.80	21.00
1253WDXXX4-14HF	14	19.25	16.25	18.05	22.25
1253WDXXX4-15HF	15	20.50	17.50	19.30	23.50

TOLERANCE		PART NO.	
X.	X.XXX ±0.10	CNT1253WD2004-XX HF	
X.X ±0.30		DRAWING NO.	
X.XX ±0.20	Angular ±2°	APPROVED BY <i>Angus.Chen</i> 2011.12.13	
	UNIT: mm	CHECKED BY <i>Sun.lee</i> 2011.12.13	DRAWN BY <i>Rock.Yu</i> 2011.12.13
DWG TYPE. <b>Customer Drawing</b>		PAGE 1 OF 1	REV. A
		SCALE 5 : 1	

CNT 肯耐特电子有限公司

TITLE. 1.25mm WAFER (VERTICAL)  
SMT TYPE

A		NEW EDITION	Rock	2011.12.13
REV.	ECN NO	REVISION RECORD	DRAW	DATE