

RoHS



HF

CUST INFORMATION.

PART NO. NA	DRAWING NO. NA	REV. NA
----------------	-------------------	------------

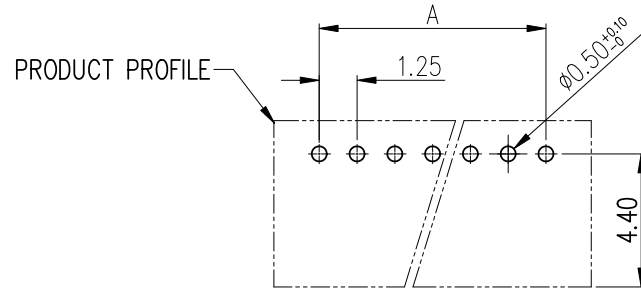
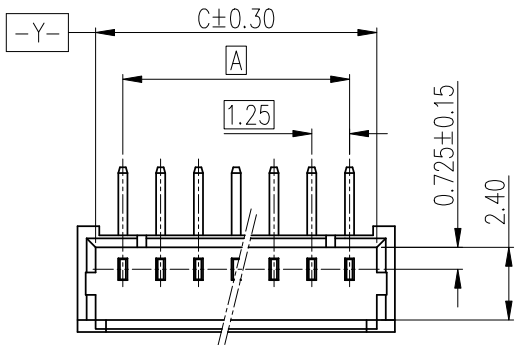

P.C.BOARD LAYOUT
TOLERANCES: ±0.05
(PCB THK=0.8)

NOTE:
1.MATERIAL:
HOUSING: THERMOPLASTIC, UL94 V-0,COLOR: NATURAL
TERMINAL: COPPER ALLOY.
2.CONTACT FINISH:
UNDERPLATING NICKEL OVERALL, DETAIL SEE NOTE9.
3.ORDER INFORMATION:
CNT1253WR X 0 X 2 - XX HF
PACKAGING: 1: BAG NO. OF POS ROW: 02~15
 2: TAPE REEL PLATING OPTIONS:
0: MATTE TIN OVERALL.
1: GOLD FLASH ON CONTACT AREA
MATTE TIN ON SOLDER AREA.

10.DIMENSIONAL & ORDERING INFORMATION:

PART NO.	POS	A	B	C
1253WRXXX2-02HF	2		4.25	3.05
1253WRXXX2-03HF	3	2.50	5.50	4.30
1253WRXXX2-04HF	4	3.75	6.75	5.55
1253WRXXX2-05HF	5	5.00	8.00	6.80
1253WRXXX2-06HF	6	6.25	9.25	8.05
1253WRXXX2-07HF	7	7.50	10.50	9.30
1253WRXXX2-08HF	8	8.75	11.75	10.55
1253WRXXX2-09HF	9	10.00	13.00	11.80
1253WRXXX2-10HF	10	11.25	14.25	13.05
1253WRXXX2-11HF	11	12.50	15.50	14.30
1253WRXXX2-12HF	12	13.75	16.75	15.55
1253WRXXX2-13HF	13	15.00	18.00	16.80
1253WRXXX2-14HF	14	16.25	19.25	18.05
1253WRXXX2-15HF	15	17.50	20.50	19.30

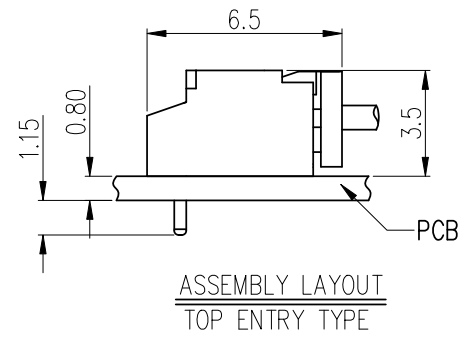
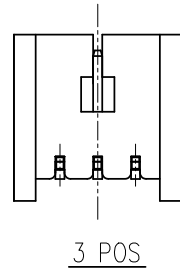
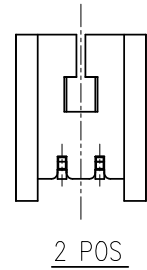
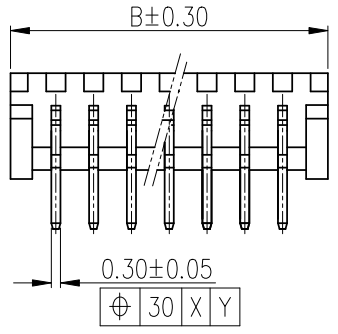
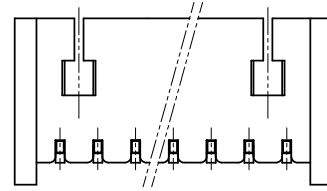
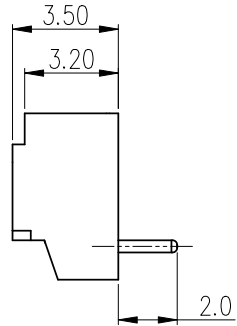
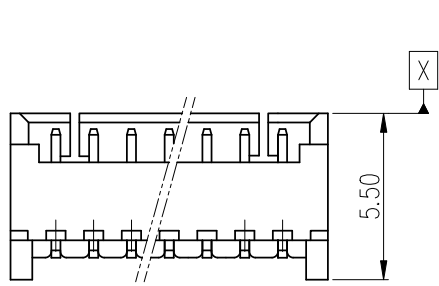

TOLERANCE		PART NO.	
X.	X.XXX ±0.10	CNT1253WRX0X2-XXHF	
X.X	±0.30	DRAWING NO.	
X.XX	±0.20	APPROVED BY	
	Angular ±2°	Angus.Chen	CHECKED BY
	UNIT: mm	2011.12.13	Sum.lee
DWG TYPE.		Rock	DRAWN BY
Customer Drawing		2011.12.13	Rock

C N T 肯耐特电子有限公司			
TITLE. 1.25mm WAFER (RIGHT ANGLE) DIP TYPE			
APPROVED BY	CHECKED BY	DRAWN BY	PAGE
Angus.Chen	Sum.lee	Rock	1 OF 1
2011.12.13	2011.12.13	2011.12.13	SCALE
			5 : 1
			REV. A

REV.	ECN NO	REVISION RECORD	DRAW	DATE
A		NEW EDITION	Rock	2011.12.13