

REV	DESCRIPTION	DATE

SPECIFICATIONS

Current Rating: 2.0 Amps
 Insulator resistance: 1000 Megohms Min.
 Dielectric withstanding: AC 500 V
 Contact Resistance: 20 Megohms Max
 Operating Temperature: -40° C - +105° C

MATERIALS

Contact Material: Brass
 Insulator Material: 30% Glass filled
 Nylon 6T UL94V-0
 Finish: Gold / Tin Plated over nickel

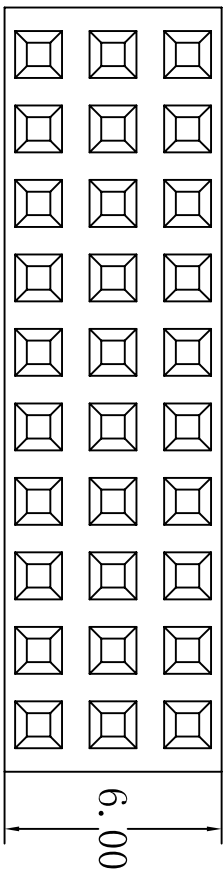

2.00 X No. of Positions + 0.30 = D ± 0.25

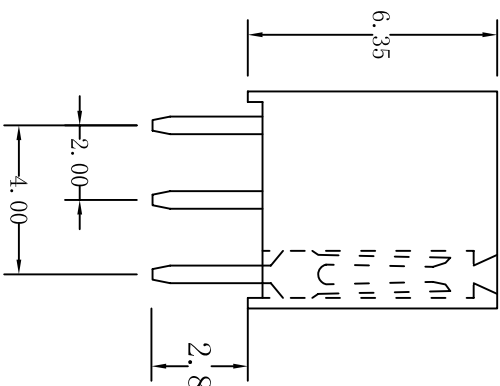
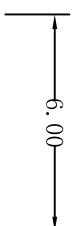
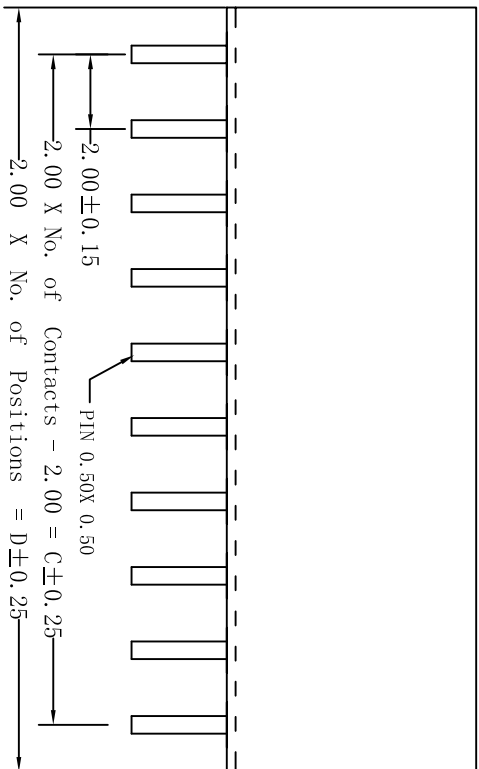

Recommended P. C. Board Hole Layout

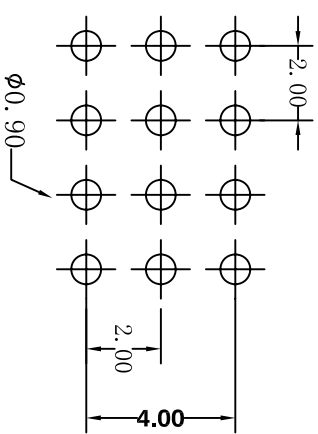

A	E
B	F
H	W

CNT 肯耐特电子有限公司

REV.	UNIT	SCALE	GENERAL TOLERANCE
1.0	mm	1:1	X. ° ± 5° . X. ° ± XX. ± 5° . XX ± 0.38 XXX. ± 5° . XXX ± 0.38

DRAWN	DATE
Ares	20080302
CHECK	DATE
Grace	20080302
APPROVE	DATE
Max	20080302

DWG. NO.	PART. NO.
	CNT-F200-3*XX-GS-635

TITLE
2.00*2.00 Female Header Triple Row Dip