

Pitch:2.00mm (0.079")

Dual Row Box Header Straight Elevator Dip Type

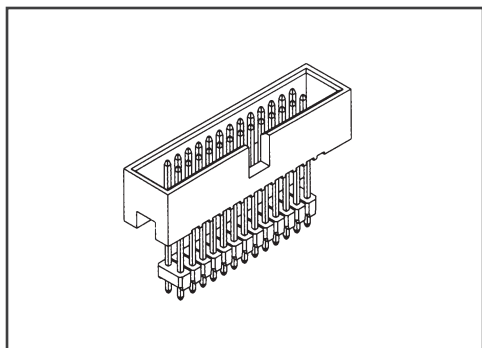

SPECIFICATIONS

Current Rating:2.0 Amps
 Insulator resistance:1000 Megohms Min.
 Dielectric withstanding:AC 500 V
 Contact Resistance:20 Megohms Max
 Operating Temperature:-40° C - +105° C

MATERIALS

Contact Material:Brass
 Insulator Material:NYLON-6T UL94V-0
 Finish:Gold/Tin Plated

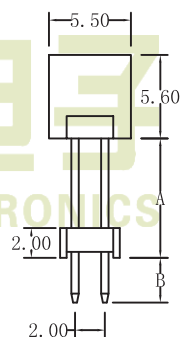
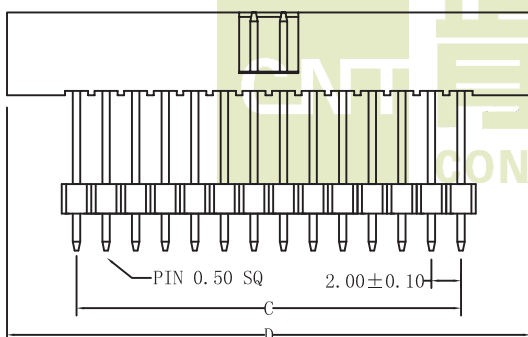

Recommended P. C. Board Hole Layout

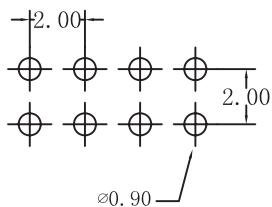

No. of Pins Per Row		05~25
Dimension		
C	2.00*No.of Contacts-2.0	±0.25
D	2.00*No.of Contacts+7.1	±0.38

Ordering Information

B 200 1 * XX G S A/B
 B: Pitch: 2: No. of pins per Row: G: GoldPlated S: Straight A/B: Custom Length Available
 Box 2.00mm Dual Row T: Tin Plated